

N-Channel MOSFET

Features

- $R_{DS(on)}$ (Max 0.023 Ω)@ $V_{GS}=10V$
- Gate Charge (Typical 25nC)
- Maximum Junction Temperature Range (175 °C)

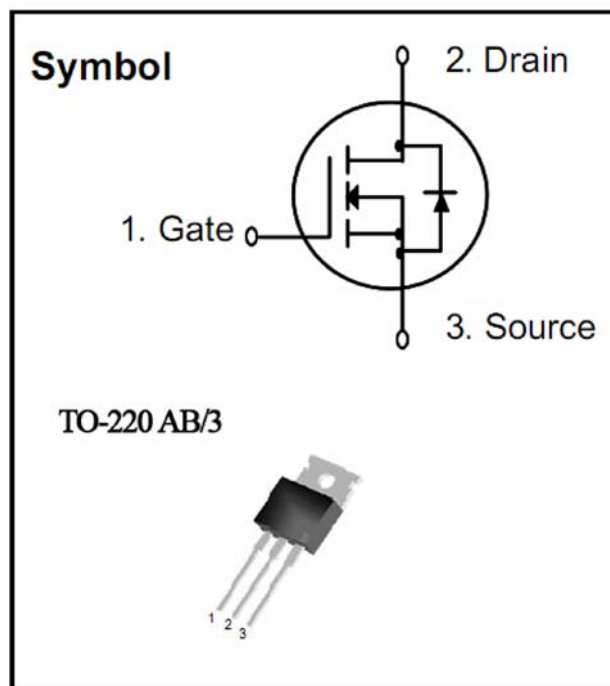

Absolute Maximum Ratings

Symbol	Parameter	Value	Units
V_{DSS}	Drain to Source Voltage	60	V
I_D	Continuous Drain Current(@ $T_C = 25\text{ }^\circ\text{C}$)	50	A
	Continuous Drain Current(@ $T_C = 100\text{ }^\circ\text{C}$)	35	A
I_{DM}	Drain Current Pulsed	200 ¹⁾	A
V_{GS}	Gate to Source Voltage	± 20	V
E_{AS}	Single Pulsed Avalanche Energy	493 ²⁾	mJ
E_{AR}	Repetitive Avalanche Energy	12.0 ¹⁾	mJ
dv/dt	Peak Diode Recovery dv/dt	7.0 ³⁾	V/ns
P_D	Total Power Dissipation(@ $T_C = 25\text{ }^\circ\text{C}$)	120	W
	Derating Factor above 25 °C	0.8	W/°C
T_{STG}	Operating Junction Temperature	-55 ~ 175	°C
T_J	Storage Temperature	150	°C

Notes

- 1) Repeativity rating : pulse width limited by junction temperature
- 2) $L = 230\text{ }\mu\text{H}$, $I_{AS} = 50\text{ A}$, $V_{DD} = 50\text{ V}$, $R_G = 25\text{ }\Omega$, Starting $T_J = 25\text{ }^\circ\text{C}$
- 3) $I_{SD} \leq 50\text{ A}$, $di/dt \leq 300\text{ A}/\mu\text{s}$, $V_{DD} \leq BV_{DSS}$, Starting $T_J = 25\text{ }^\circ\text{C}$

Thermal Characteristics

Symbol	Parameter	Value			Units
		Min.	Typ.	Max.	
$R_{\theta JC}$	Thermal Resistance, Junction-to-Case	-	-	1.24	$^{\circ}\text{C/W}$
$R_{\theta JA}$	Thermal Resistance, Junction-to-Ambient*	-	0.5	-	$^{\circ}\text{C/W}$
$R_{\theta JA}$	Thermal Resistance, Junction-to-Ambient	-	-	62.5	$^{\circ}\text{C/W}$

* When mounted on the minimum pad size recommended (PCB Mount)

Source-Drain Diode Characteristics and Maximum Ratings

Symbol	Parameter	Test Conditions	Min	Typ	Max	Units
I_S	Maximum Continuous Source-Drain Diode Forward Current		-	-	50	A
I_{SM}	Maximum Pulsed Source-Drain Diode Forward Current		-	-	200	
V_{SD}	Diode Forward Voltage	$I_S = 50\text{ A}, V_{GS} = 0\text{ V}$	-	-	1.5	V
t_{rr}	Reverse Recovery Time	$I_S = 50\text{ A}, V_{GS} = 0\text{ V}, dI/dt = 100\text{ A/us}$	-	50	-	ns
Q_{rr}	Reverse Recovery Charge		-	70	-	μC

Electrical Characteristics ($T_C = 25\text{ }^\circ\text{C}$ unless otherwise noted)

Symbol	Parameter	Test Conditions	Min	Typ	Max	Units
Off Characteristics						
BV_{DSS}	Drain-Source Breakdown Voltage	$V_{GS} = 0\text{ V}$, $I_D = 250\text{ }\mu\text{A}$	60	-	-	V
$\Delta BV_{DSS}/\Delta T_J$	Breakdown Voltage Temperature coefficient	$I_D = 250\text{ }\mu\text{A}$, referenced to $25\text{ }^\circ\text{C}$	-	0.07	-	V/ $^\circ\text{C}$
I_{DSS}	Drain-Source Leakage Current	$V_{DS} = 60\text{ V}$, $V_{GS} = 0\text{ V}$	-	-	10	μA
		$V_{DS} = 48\text{ V}$, $T_C = 125\text{ }^\circ\text{C}$	-	-	100	μA
I_{GSS}	Gate-Source Leakage, Forward	$V_{GS} = 20\text{ V}$, $V_{DS} = 0\text{ V}$	-	-	100	nA
	Gate-source Leakage, Reverse	$V_{GS} = -20\text{ V}$, $V_{DS} = 0\text{ V}$	-	-	-100	nA
On Characteristics						
$V_{GS(th)}$	Gate Threshold Voltage	$V_{DS} = V_{GS}$, $I_D = 250\text{ }\mu\text{A}$	2.0	-	4.0	V
$R_{DS(ON)}$	Static Drain-Source On-state Resistance	$V_{GS} = 10\text{ V}$, $I_D = 25.0\text{ A}$	-	0.018	0.022	Ω
Dynamic Characteristics						
C_{iss}	Input Capacitance	$V_{GS} = 0\text{ V}$, $V_{DS} = 25\text{ V}$, $f = 1\text{ MHz}$	-	1050	1365	pF
C_{oss}	Output Capacitance		-	460	600	
C_{rss}	Reverse Transfer Capacitance		-	70	90	
Dynamic Characteristics						
$t_{d(on)}$	Turn-on Delay Time	$V_{DD} = 30\text{ V}$, $I_D = 25.0\text{ A}$, $R_G = 25\text{ }\Omega$ Pulse Width $\leq 300\mu\text{s}$, $Q > 50$	-	20	50	ns
t_r	Rise Time		-	100	210	
$t_{d(off)}$	Turn-off Delay Time		-	80	170	
t_f	Fall Time		-	85	180	
Q_g	Total Gate Charge	$V_{DS} = 48\text{ V}$, $V_{GS} = 10\text{ V}$, $I_D = 50\text{ A}$	-	32	42	nC
Q_{gs}	Gate-Source Charge		-	8	-	
Q_{gd}	Gate-Drain Charge(Miller Charge)		-	12	-	

Chip size

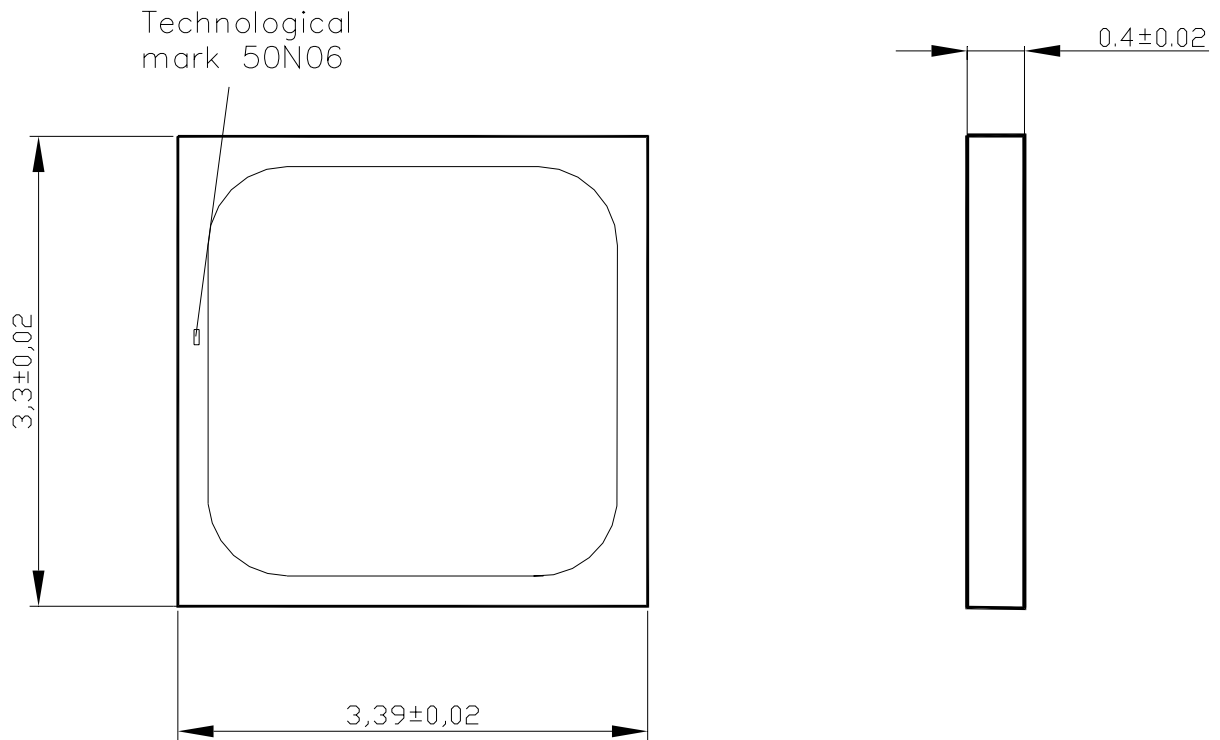

Package Chip

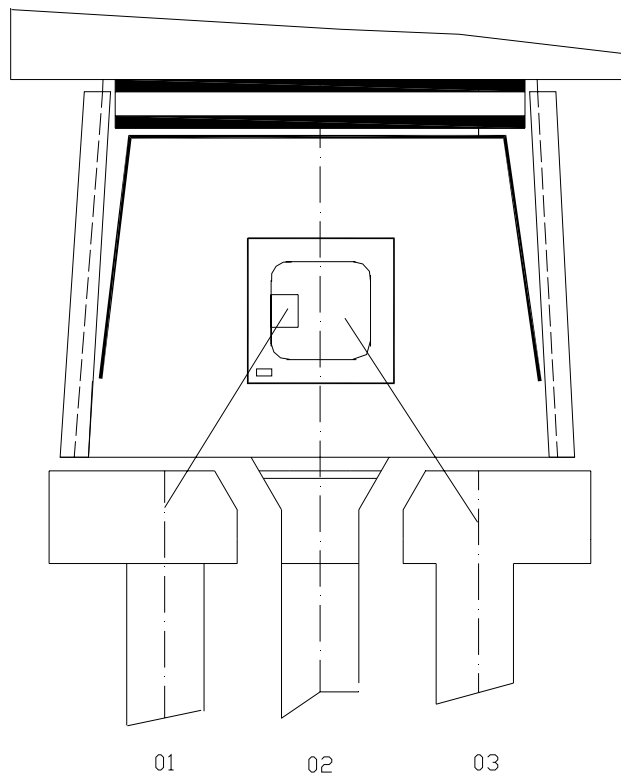

Package Dimensions TO-220 AB/3

