

IN1705D

POWER SUPPLY CHECK MICROCIRCUIT WITH HOST PRIMARY SUPPLY MONITORING CIRCUIT

IN1705D microcircuit is purposed to check power supply and to start up microcontroller and microprocessor systems. It is applied to ensure regular standard operation of the circuit when the device is switched on/off and also when there is alarm emergency dropping of supply voltage.

Physically the microcircuit is made in 8-pin SO-package MS012AA.

LSIIC Characteristics:

- Standard supply voltage 5,0 B
- Operation temperature range $T_A =$ from -40° to $+85^{\circ}\text{C}$
- RESET signal generation when power supply is provided for regular start-up of microprocessor

RESET signal generation when power supply is dropped below operation one to exclude incorrect operation of microprocessor.

- RESET signal generation when reset key is pressed
- Option of threshold voltage programming when RESET signal is generated

Microcircuit includes:

- reference voltage source
- two analog comparators
- guard timer
- digitizer, (digital sampler)
- digital delay

Pins' designation in package

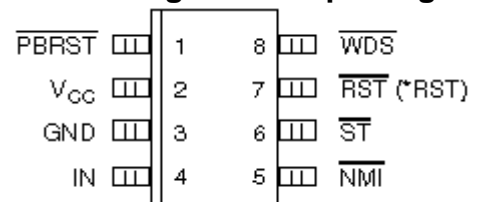

Functions performed

- RESET signal generation by fixed supply voltage level
- RESET signal generation from external RESET key
- Generation of guard timer state signal
- Alarm interrupt of host power supply

Architecture diagramme

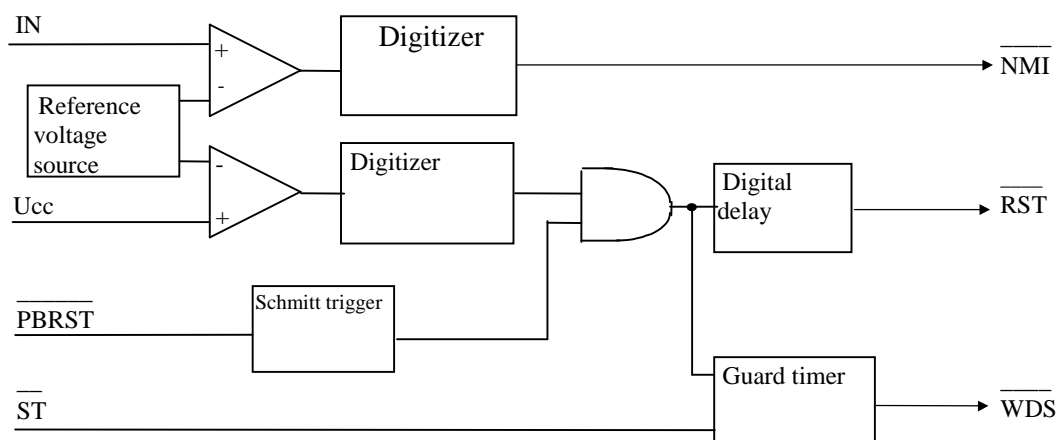

Microcircuit pins' purpose

IN1705D

Pin	Symbol	Name	Type
01	$\overline{\text{PBRST}}$	Reset form external key	Input
02	Ucc	Supply voltage pin	-
03	GND	Common pin	-
04	IN	Host source check	Input
05	$\overline{\text{NMI}}$	Non-masked interrupt	Output
06	$\overline{\text{ST}}$	Guard timer strobe	Input
07	$\overline{\text{RST}}$	Reset actibe low	Output
08	$\overline{\text{WDS}}$	Guard timer state	Output

Operation temperature range

Operation temperature range от -40°C до +85°C.

Limiting\tolerable conditions

Parameter Symbol	Name	Norm		Units
		not less	not more	
U _{CC}	Supply voltage	4,5	5,5	V
U _{IH}	High level input voltage	2,0	U _{CC} +0,3	V
U _{IL}	Low level input voltage	-0,03	0,5	V
T _A	Operation temperature range	-40	+85	°C

Tolerable conditions

Parameter symbol	Name	Norm		Unit
		not less	not more	
U _{CC}	Supply voltage	-0,5	7,0	V
U _{IH}	High level input voltage	-	U _{CC} +0,5	V
U _{IL}	Low level input voltage	-0,5	-	V
T _{stg}	Storage temperature	-60	+125	°C

IN1705D

Microcircuit serviceability is not guaranteed when limiting conditions are applied. After limiting conditions are withdrawn the serviceability will be guaranteed in limiting tolerable condition.

Static parameters

Parameter symbol	Nme	Measurement conditions	Norm		Units
			not less	not more	
U_{IL}	Low level input voltage	U_{CC} =from 4,5 to 5,5V	-	0,5	V
U_{IH}	High level input voltage	U_{CC} =from 4,5 to 5,5V	2,0		V
I_{OL}	Low level output current	U_{CC} =from 4,5 to 5,5V U_{OL} =0,4V	10,0	-	mA
U_{OH}	High level output voltage	U_{CC} =from 4,5 to 5,5V I_{OH} =-500 mA	U_{CC} -0,3	-	V
$-I_{LIL}$	Low level input leakage current (IN)	U_{CC} =from 4,5 to 5,5V $U_I = U_{CC}$ or U_{SS}	-	1,0	mA
$-I_{LIL}$	Low level input leakage current (ST)	U_{CC} =from 4,5 to 5,5V $U_I = U_{CC}$ or U_{SS}	10	100	mA
$-I_{LIL}$	Low level input leakage current (PBRST)	U_{CC} =from 4,5 to 5,5V $U_I = U_{CC}$ or U_{SS}	50	450	mA
I_{LIH}	High level input leakage current	U_{CC} =from 4,5 to 5,5V $U_I = U_{CC}$ or U_{SS}	-	1,0	mA
I_{CC}	Dynamic consumption current	U_{CC} =from 4,5 to 5,5V $U_{IL} = U_{SS}$, $U_{IH} = U_{CC}$	-	60	mA
U_{CCTP}	Source voltage when reset signal is generated	U_{CC} =from 4,5 to 5,5V $U_{IL} = U_{SS}$, $U_{IH} = U_{CC}$	4,5	4,75	V
U_{TP}	IN input voltage when interrupt is generated	U_{CC} =from 4,5 to 5,5V $U_{IL} = U_{SS}$, $U_{IH} = U_{CC}$	1,2	1,3	V

Dynamic parameters

U_{CC} = from 4,5 to 5,5V, T_A = from -40° to +85°C

Parameter symbol	Name	Norm		Unit
		not less	not more	
t_{TD}	Guard timer reflow time	1,0	2,2	s
t_{PDLY}	Setting time for reset by PBRST signal	-	250	ns
t_{RST}	Reset hold-in time by PBRST signal	130	285	ms
t_{RPD}	Setting time for reset by U_{CC}	-	8,0	mks
t_{RPU}	Hold-in time for reset by U_{CC}	130	285	ms
t_{IPD}	Interrupt setting time for IN input	-	8,0	mks
t_{PB}	Key press duration (PBRST = U_{IL})	150	-	ns
t_{ST}	Strobe pulse width	10	-	ns

Time diagrammes

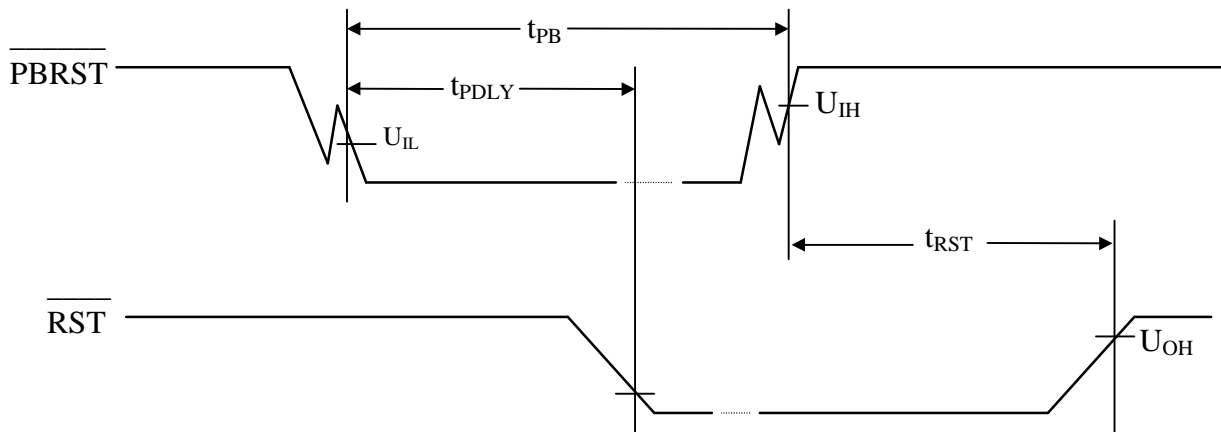

Fig.1 - Time diagramme of generation guard timer state signal.

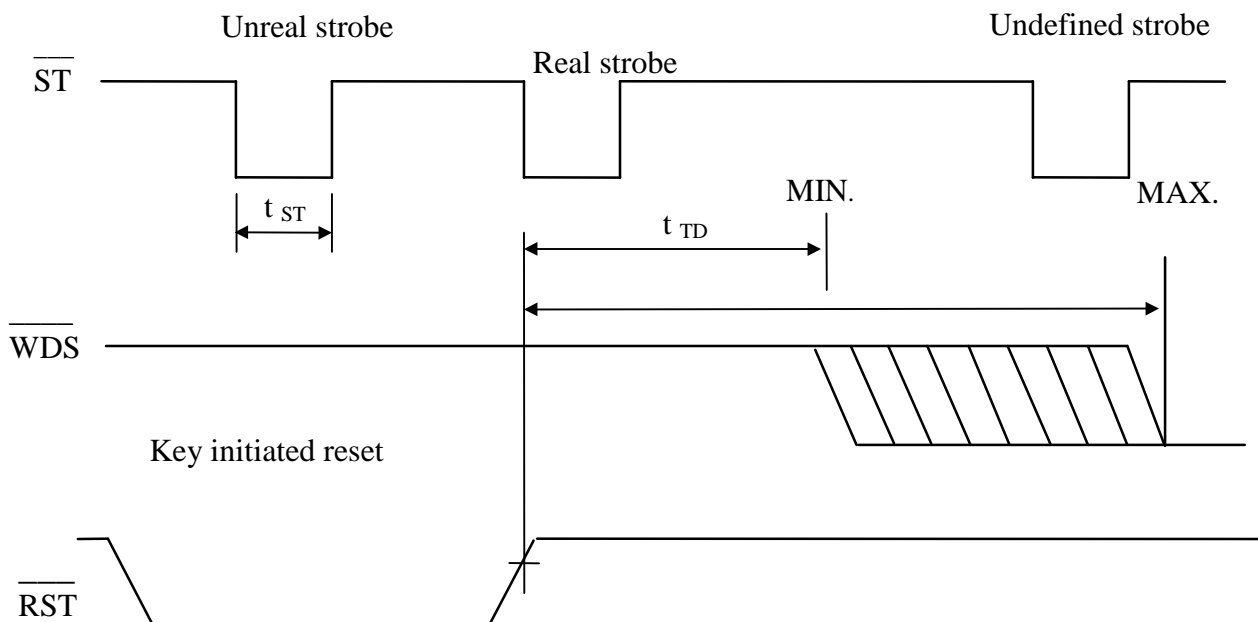

Fig.2 - Time diagramme of generation guard timer state signal (strobed input)

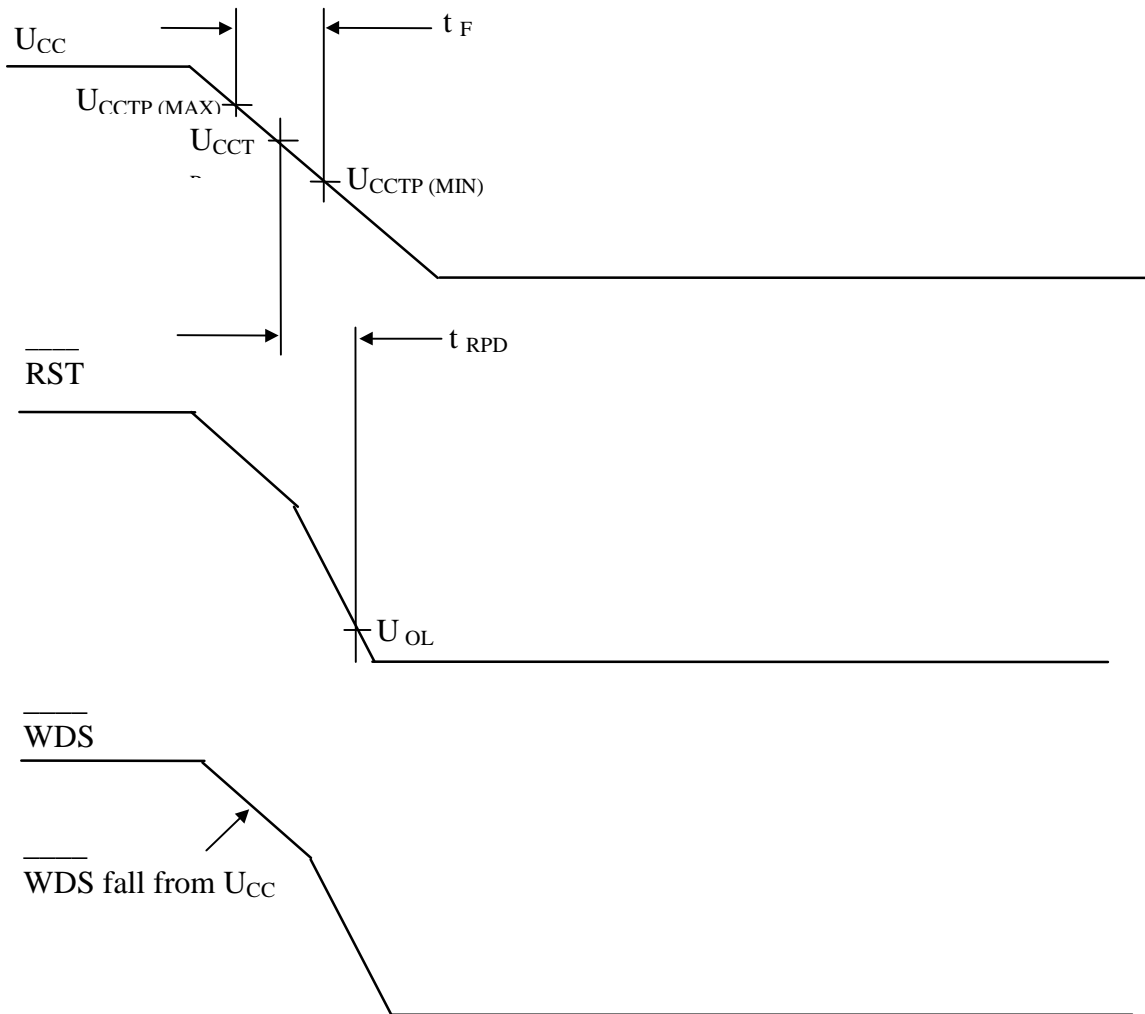

Fig. 3 - Time diagram of generation reset signal when power supply is dropped up to U_{strobe} (power supply error)

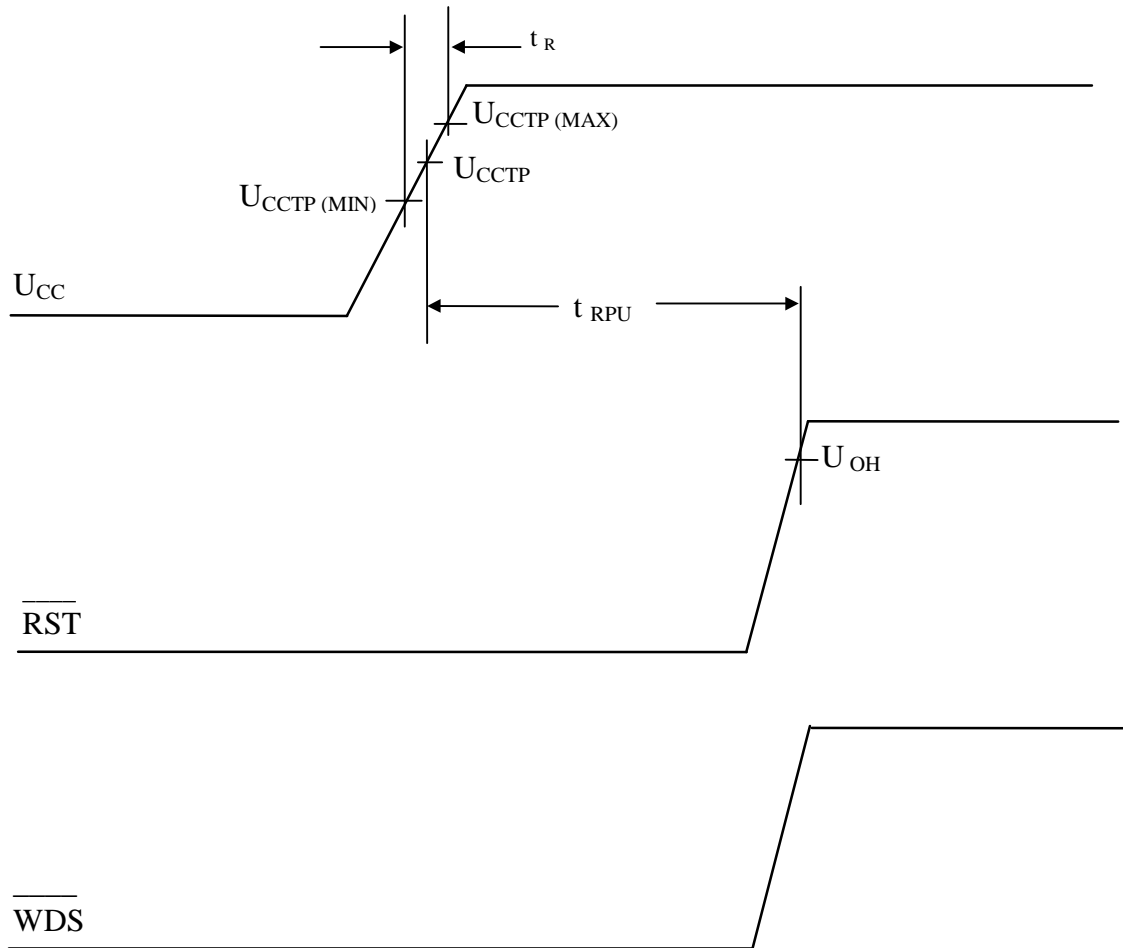

Fig. 4 - Time diagramme fo power supply connection (reset signal is reset active after power supply is transferred to stable state)

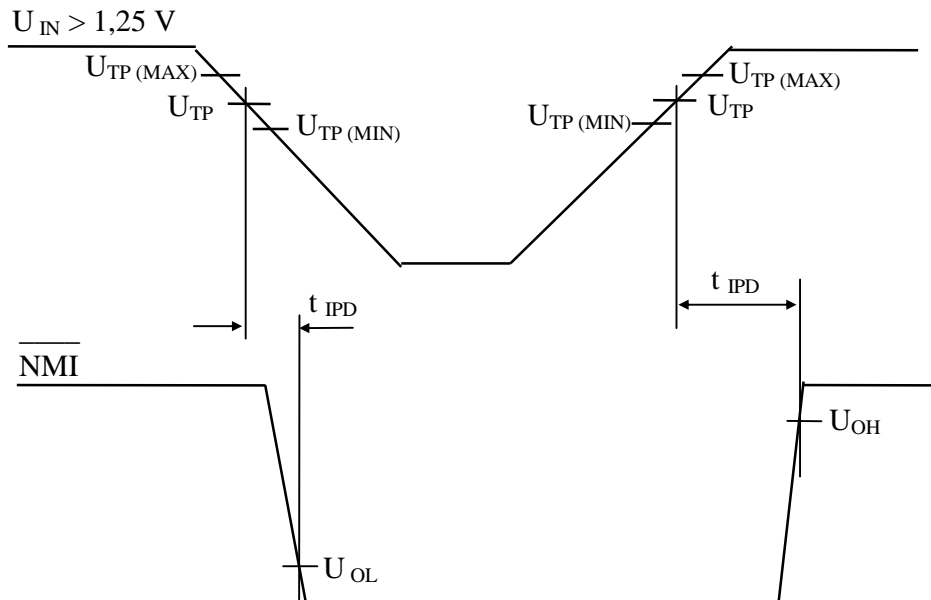

Fig. 5 - Time diagrammed of non-masked interrupt.