

## N-Channel MOSFET

### Features

- $R_{DS(on)}$  (Max 2.5  $\Omega$ )@ $V_{GS}=10$  V
- Gate Charge (Typical 15 nC)
- Maximum Junction Temperature Range (150 °C)

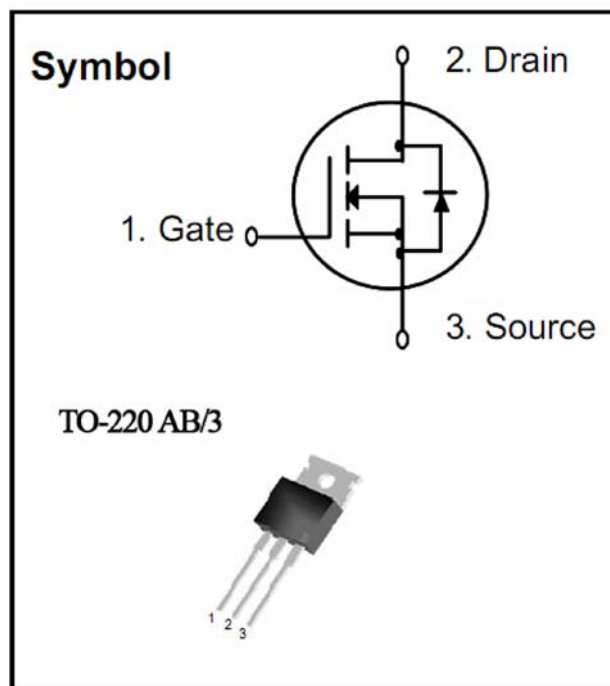

### Absolute Maximum Ratings

Symbol	Parameter	Value	Units
$V_{DSS}$	Drain to Source Voltage	600	V
$I_D$	Continuous Drain Current(@ $T_C = 25$ °C)	4.0	A
	Continuous Drain Current(@ $T_C = 100$ °C)	2.5	A
$I_{DM}$	Drain Current Pulsed	16 <sup>..1)</sup>	A
$V_{GS}$	Gate to Source Voltage	$\pm 30$	V
$E_{AS}$	Single Pulsed Avalanche Energy	240 <sup>..2)</sup>	mJ
$E_{AR}$	Repetitive Avalanche Energy	10 <sup>..1)</sup>	mJ
dv/dt	Peak Diode Recovery dv/dt	4.5 <sup>..3)</sup>	V/ns
$P_D$	Total Power Dissipation(@ $T_C = 25$ °C)	100	W
	Derating Factor above 25 °C	0.80	W/°C
$T_{STG}$	Operating Junction Temperature	-55 ~ 150	°C
$T_J$	Storage Temperature	150	°C

### Notes

- 1). Repeativity rating : pulse width limited by junction temperature
- 2).  $L = 27.5$  mH,  $I_{AS} = 4.0$  A,  $V_{DD} = 50$  V,  $R_G = 25$   $\Omega$  , Starting  $T_J = 25$  °C
- 3).  $I_{SD} \leq 4.0$  A,  $di/dt \leq 200$  A/us,  $V_{DD} \leq BV_{DSS}$ , Starting  $T_J = 25$  °C

## Thermal Characteristics

Symbol	Parameter	Value			Units
		Min.	Typ.	Max.	
$R_{\theta JC}$	Thermal Resistance, Junction-to-Case	-	-	1.25	$^{\circ}\text{C}/\text{W}$
$R_{\theta JA}$	Thermal Resistance, Junction-to-Ambient	-	0.5	-	$^{\circ}\text{C}/\text{W}$
$R_{\theta JA}$	Thermal Resistance, Junction-to-Ambient	-	-	62.5	$^{\circ}\text{C}/\text{W}$

## Source-Drain Diode Characteristics and Maximum Ratings

Symbol	Parameter	Test Conditions	Min	Typ	Max	Units
$I_S$	Maximum Continuous Source-Drain Diode Forward Current		-	-	4.0	A
$I_{SM}$	Maximum Pulsed Source-Drain Diode Forward Current		-	-	16	
$V_{SD}$	Drain-Source Diode Forward Voltage	$I_S = 4.0 \text{ A}, V_{GS} = 0 \text{ V}$	-	-	1.4	V
$t_{rr}$	Reverse Recovery Time	$I_S = 4.0 \text{ A}, V_{GS} = 0 \text{ V},$ $dI_F/dt = 100 \text{ A/us}$	-	300	-	ns
$Q_{rr}$	Reverse Recovery Charge	Pulse Width $\leq 300 \text{ us},$ $Q > 50$	-	2.2	-	$\mu\text{C}$

Electrical Characteristics (  $T_C = 25\text{ }^\circ\text{C}$  unless otherwise noted )

Symbol	Parameter	Test Conditions	Min	Typ	Max	Units
<b>Off Characteristics</b>						
$BV_{DSS}$	Drain-Source Breakdown Voltage	$V_{GS} = 0\text{ V}$ , $I_D = 250\text{ }\mu\text{A}$	600	-	-	V
$\Delta BV_{DSS}/\Delta T_J$	Breakdown Voltage Temperature coefficient	$I_D = 250\text{ }\mu\text{A}$ , referenced to $25\text{ }^\circ\text{C}$	-	0.60	-	V/ $^\circ\text{C}$
$I_{DSS}$	Drain-Source Leakage Current	$V_{DS} = 600\text{ V}$ , $V_{GS} = 0\text{ V}$	-	-	10	$\mu\text{A}$
		$V_{DS} = 480\text{ V}$ , $T_C = 125\text{ }^\circ\text{C}$	-	-	100	$\mu\text{A}$
$I_{GSS}$	Gate-Source Leakage, Forward	$V_{GS} = 30\text{ V}$ , $V_{DS} = 0\text{ V}$	-	-	100	nA
	Gate-source Leakage, Reverse	$V_{GS} = -30\text{ V}$ , $V_{DS} = 0\text{ V}$	-	-	-100	nA
<b>On Characteristics</b>						
$V_{GS(th)}$	Gate Threshold Voltage	$V_{DS} = V_{GS}$ , $I_D = 250\text{ }\mu\text{A}$	2.0	-	4.0	V
$R_{DS(ON)}$	Static Drain-Source On-state Resistance	$V_{GS} = 10\text{ V}$ , $I_D = 2.0\text{ A}$	-	2.0	2.5	$\Omega$
<b>Dynamic Characteristics</b>						
$C_{iss}$	Input Capacitance	$V_{GS} = 0\text{ V}$ , $V_{DS} = 25\text{ V}$ , $f = 1\text{ MHz}$	-	545	710	pF
$C_{oss}$	Output Capacitance		-	60	80	
$C_{rss}$	Reverse Transfer Capacitance		-	8	11	
<b>Dynamic Characteristics</b>						
$t_{d(on)}$	Turn-on Delay Time	$V_{DD} = 300\text{ V}$ , $I_D = 4.0\text{ A}$ , $R_G = 25\text{ }\Omega$ Pulse Width $\leq 300\mu\text{s}$ , $Q > 50$	-	10	30	ns
$t_r$	Rise Time		-	35	80	
$t_{d(off)}$	Turn-off Delay Time		-	45	100	
$t_f$	Fall Time		-	40	90	
$Q_g$	Total Gate Charge	$V_{DS} = 480\text{ V}$ , $V_{GS} = 10\text{ V}$ , $I_D = 4.0\text{ A}$	-	15	20	nC
$Q_{gs}$	Gate-Source Charge		-	2.8	-	
$Q_{gd}$	Gate-Drain Charge (Miller Charge)		-	6.5	-	

**Chip size**

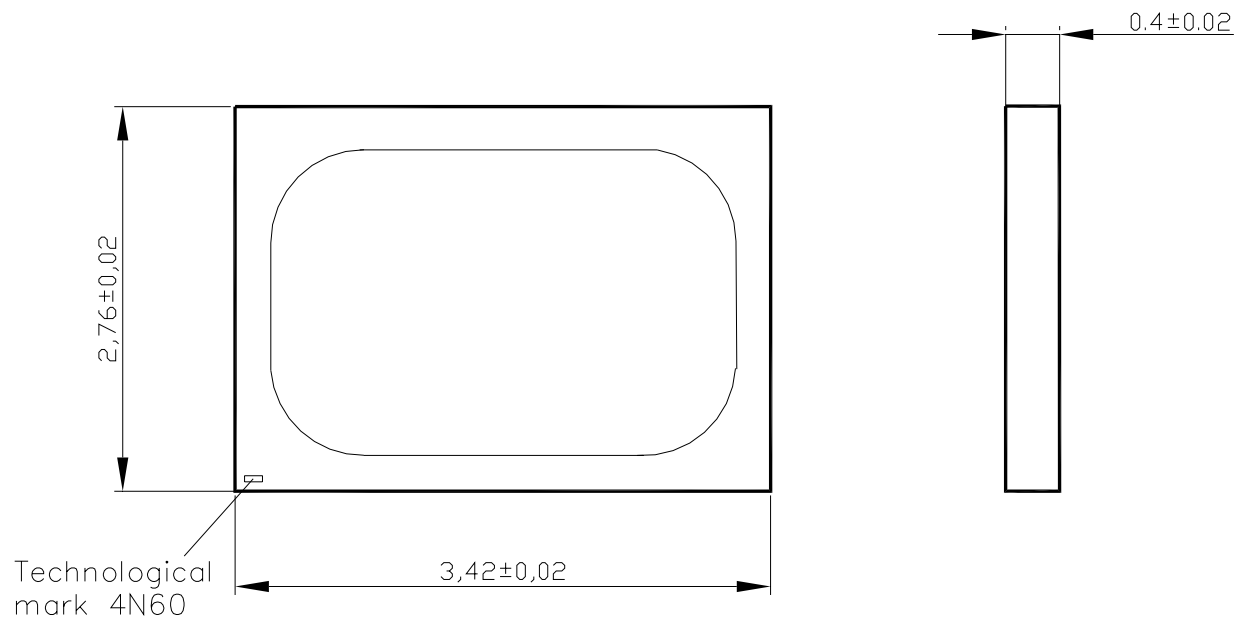

Wafer diameter, mm	Scribe line width	front side metal	Back side metal	Gate, $\mu\text{m}$
150	80	Al /1%Si $3.0 \pm 0.3$	Ti $0.1 \pm 0.02$ NiV $0.5 \pm 0.1$ Ag $0.6 \pm 0.1$	576x463

**Package Chip**

